

WMT52 Ultrasonic Wind Sensor for Accurate and Stable Measurement



The Vaisala WINDCAP® Ultrasonic Wind Sensor WMT52 - stable and inexpensive wind measurement for demanding applications.

Features/Benefits

- Measures horizontal wind speed and wind direction
- Triangular design ensures excellent data availability
- No moving parts
- Maintenance-free
- Optional heating available
- Compact, durable and robust
- Low power consumption
- IP66 housing with mounting kit
- Applications: marine, wind energy, environmental monitoring

Proven Vaisala performance

The Vaisala WINDCAP® Ultrasonic Wind Sensor WMT52 incorporates decades of Vaisala experience in wind measurement using ultrasound to determine horizontal wind speed and direction.

With no moving parts, the WMT52 has high sensitivity as the measurement time constant and starting threshold are virtually zero. This makes it superior to the conventional mechanical wind sensors.

The WMT52 is also very economical; there is no need for field calibration or maintenance.

Applications

The WMT52 is ideal for use in marine applications as the housing with the mounting kit is water resistant. The WMT52 is also suitable for wind energy and environmental monitoring, for example, for measuring the distribution of air pollution and road tunnel ventilation.

Easy to install

The WMT52 is delivered fully assembled and configured from the factory. With the Vaisala Configuration Software Tool you can change the settings, such as averaging times, output mode, update intervals, measured variables and message contents.

The WMT52 can be mounted either on top of a pole mast or on a cross arm.

When using the optional mounting kit, the north alignment needs to be performed only once.

Heating

You can also measure wind in freezing weather conditions and during snowfall, thanks to the optional heating available in the WMT52.

As the heating circuit is independent of the operational power, separate supplies can be used. Heating is switched on automatically at low temperatures, well before the freezing point.

Low power consumption

The WMT52 has very low power consumption; during the idle mode the device typically consumes about 2 ... 3 mW.



The WMT52 is ideal for an offshore windmill.

Technical Data

Wind

Wind speed

Range	0 ... 60 m/s
Response time	250 ms
Available variables	average, maximum, and minimum
Accuracy	
0 ... 35 m/s	±0.3 m/s or ±3 % whichever is greater
35 m/s ... 60 m/s	±5 %
Output resolution	0.1 m/s (km/h, mph, knots)

Wind direction

Azimuth	0 ... 360°
Response time	250 ms
Available variables	average, maximum, and minimum
Accuracy	±3°
Output resolution	1°

Measurement frame

Averaging time	1 ... 3600 s (=60 min), at one second steps on the basis of samples taken at 4 Hz rate (configurable)
Update interval	1 ... 3600 s (=60 min), at one-second steps

General

Self-diagnostics	separate supervision message, unit/status fields to validate measurement quality
Start-up	automatic, <10 s from power on to the first valid output
Serial data interface	SDI-12, RS-232, RS-485, RS-422, USB connection
Communication protocols	SDI-12 v1.3, ASCII automatic & polled, NMEA 0183 v. 3.0 with query option
Baud rate	1200 ... 115 200
Operating temperature	-52 ... +60 °C (-60 ... +140 °F)
Storage temperature	-60 ... +70 °C (-76 ... +158 °F)
Dimensions	
height	139 mm (5.47")
diameter	114 mm (4.49")
weight	510 g (1.12 lb)
Housing	IP65
Housing with mounting kit	IP66
Vibration	IEC 60945 paragraph 8

Power supply

Input voltage	5 ... 32 VDC
Power consumption on average	
minimum	0.1 mA at 12 VDC
maximum	14 mA at 5 VDC
typical	3 mA at 12 VDC
	(default measuring intervals)
Heating voltage	5 ... 32 VDC (or AC, max. 30 V _{RMS})

Accessories

Mounting kit	212792
Bird spike kit	212793
Surge protector for sensor	WSP150

Electromagnetic compatibility

Complies with EMC standard: EN61326-1, Industrial Environment
IEC standards IEC 60945/61000-4-2 ... 61000-4-6

Dimensions

Dimensions in mm (inches)

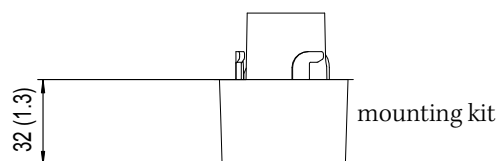
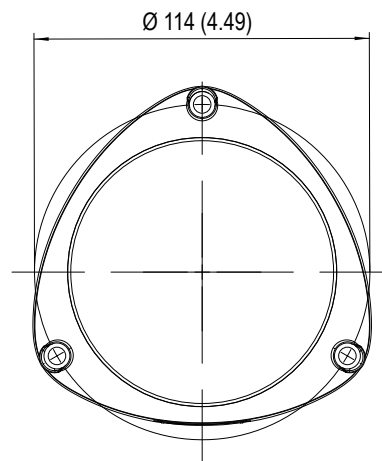
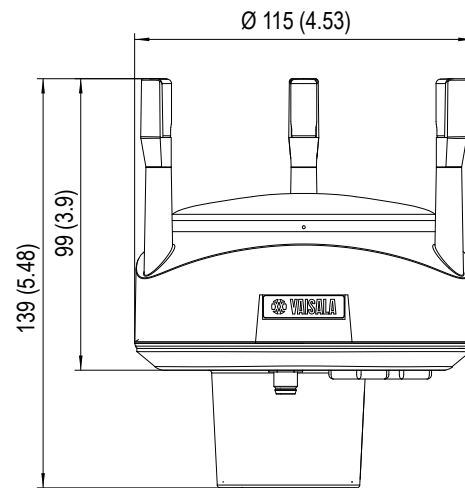

WINDCAP® is a registered trademark of Vaisala.
Specifications are subject to change without prior notice.
©Vaisala Oyj

