

# USER'S GUIDE



## Vaisala HUMICAP<sup>®</sup> Humidity and Temperature Transmitter Series HMT100



PUBLISHED BY

Vaisala Oyj  
P.O. Box 26  
FIN-00421 Helsinki  
Finland

Phone (int.): +358 9 8949 1  
Fax: +358 9 8949 2227

Visit our Internet pages at <http://www.vaisala.com/>

© Vaisala 2006

No part of this manual may be reproduced in any form or by any means, electronic or mechanical (including photocopying), nor may its contents be communicated to a third party without prior written permission of the copyright holder.

The contents are subject to change without prior notice.

Please observe that this manual does not create any legally binding obligations for Vaisala towards the customer or end user. All legally binding commitments and agreements are included exclusively in the applicable supply contract or Conditions of Sale.

---

# Table of Contents

## CHAPTER 1

|   |          |
|---|----------|
| <b>GENERAL INFORMATION</b> .....                | <b>5</b> |
| <b>About This Manual</b> .....                  | <b>5</b> |
| Version Information .....                       | 5        |
| Related Manuals .....                           | 5        |
| General Safety Considerations .....             | 6        |
| Feedback.....                                   | 6        |
| <b>Product Related Safety Precautions</b> ..... | <b>6</b> |
| <b>ESD Protection</b> .....                     | <b>7</b> |
| <b>Recycling</b> .....                          | <b>7</b> |
| <b>Trademarks</b> .....                         | <b>8</b> |
| <b>License Agreement</b> .....                  | <b>8</b> |
| <b>Warranty</b> .....                           | <b>9</b> |

## CHAPTER 2

|  |           |
|--|-----------|
| <b>PRODUCT OVERVIEW</b> .....  | <b>11</b> |
| <b>Introduction to the HMT100 Humidity and Temperature Transmitter</b> ..... | <b>11</b> |
| Product Description.....   | 11        |
| Fixed and Remote Probe Models .....  | 12        |
| Optional Display .....   | 12        |
| HMT100 Transmitter Components.....   | 13        |

## CHAPTER 3

|   |           |
|---|-----------|
| <b>INSTALLATION</b> .....                             | <b>15</b> |
| <b>Mounting</b> .....                                 | <b>15</b> |
| Wall Mounting .....                                   | 15        |
| With Plastic Wall Assembly Plate (Provided).....      | 15        |
| With Optional Aluminium Wall Installation Plate ..... | 16        |
| Installation with Rain Shield .....                   | 17        |
| Installation with Radiation Shield .....              | 18        |
| Duct Installation Kit .....                           | 19        |
| Probe Assembly with Duct Installation Kit .....       | 20        |
| Drilling Instructions for Duct Installation Kit ..... | 21        |
| <b>Connections</b> .....                              | <b>22</b> |

CHAPTER 4

**MAINTENANCE.....25**

**Replacing the HUMICAP® Sensor .....25**

        Fixed Probe Model .....25

        Remote Probe Model .....25

**Removing and Fastening the Probe .....26**

        Fixed Probe Model .....26

        Remote Probe Model .....27

**Calibration and Adjustment.....28**

        Relative Humidity Adjustment Using the Push-Buttons .....28

        Adjustment with HM70 .....29

            Field Checking and Adjustment Using a Calibrated Reference Probe .....30

            One-Point Adjustment Using a Calibrator .....31

            Two-Point Adjustment Using a Calibrator .....32

            LiCl-NaCl Adjustment.....33

            Temperature Field Check and Adjustment by Using a Calibrated Reference Probe.....34

        Adjustment with HMI41 .....35

            Connections and Selecting the Calibrator Function .....36

            Offset and Gain Adjustments .....37

                HMI41 as a Reference Meter .....38

                HMI41 as a Terminal.....39

            Troubleshooting.....40

**Analog Output Tests .....41**

CHAPTER 5

**TROUBLESHOOTING.....43**

**Error Mode.....43**

        Current Output.....43

        Voltage Output.....43

**Technical Support .....43**

**Return Instructions .....44**

**Vaisala Service Centers .....44**

CHAPTER 6

**TECHNICAL DATA .....45**

**Specifications .....45**

**Dimensions in mm (inches).....49**

---

## List of Figures

|           |  |    |
|-----------|--|----|
| Figure 1  | HMT100 Components .....  | 13 |
| Figure 2  | Plastic Wall Assembly Plate .....                                | 15 |
| Figure 3  | Plastic Wall Assembly Plate with Aluminium Installation Plate    | 16 |
| Figure 4  | HMT100 Installation with Rain Shield .....                       | 17 |
| Figure 5  | Installation of the Humidity Probe with the Radiation Shield.... | 18 |
| Figure 6  | Probe Installation with the Duct Installation Kit .....          | 19 |
| Figure 7  | Assembly of the Humidity Probe with the Duct Installation Kit.   | 20 |
| Figure 8  | Drilling Instructions .....                                      | 21 |
| Figure 9  | HMT100 Connection Board.....                                     | 22 |
| Figure 10 | (1) Isolated Current-Loop Wiring, (2) Voltage Output Wiring ...  | 23 |
| Figure 11 | Removing the Humidity Probe (Fixed Probe Model).....             | 26 |
| Figure 12 | Removing the Humidity Probe (Remote Probe Model) .....           | 27 |
| Figure 13 | Adjustment Buttons .....   | 28 |
| Figure 14 | Location of the MI70 Probe and Cable Connector Ports .....       | 29 |
| Figure 15 | Example of the MI70 Adjustment Menu .....                        | 31 |
| Figure 16 | Example of the MI70 Adjustment Mode Graph Display .....          | 31 |
| Figure 17 | Location of the HMI41 Calibration Connector .....                | 35 |
| Figure 18 | Accuracy of Temperature Measurement.....                         | 46 |
| Figure 19 | Dimensions HMT100 Fixed Probe Model .....                        | 49 |
| Figure 20 | Dimensions HMT100 Remote Probe Model.....                        | 50 |

## List of Tables

|          |  |    |
|----------|--|----|
| Table 1  | Manual Revisions .....   | 5  |
| Table 2  | Related Manuals .....  | 5  |
| Table 3  | Wiring Table .....   | 23 |
| Table 4  | Common Problems During Adjustment and Their Remedies ..            | 40 |
| Table 5  | Relative Humidity Measurement Specifications .....                 | 45 |
| Table 6  | Temperature Measurement Specifications .....                       | 45 |
| Table 7  | Dewpoint Temperature (Calculated) Measurement Specifications ..... | 46 |
| Table 8  | Accuracy of Dewpoint Temperature Measurement.....                  | 46 |
| Table 9  | Operating Environment Specifications .....                         | 46 |
| Table 10 | Inputs and Outputs .....   | 47 |
| Table 11 | Mechanics Specifications .....                                     | 47 |
| Table 12 | Options and Accessories.....                                       | 48 |

This page intentionally left blank.

# CHAPTER 1

## GENERAL INFORMATION

This chapter provides general notes for the manual and the product.

### About This Manual

This manual provides information for installing, operating, and maintaining the Humidity and Temperature Transmitter HMT100.

### Version Information

**Table 1** Manual Revisions

| Manual Code | Description  |
|-------------|--|
| M210701EN-A | 1st version, June 2005   |
| M210701EN-B | 2nd version, this manual, April 2006, wiring table (Table 3) corrected |

### Related Manuals

**Table 2** Related Manuals

| Manual Code | Manual Name  |
|-------------|--|
| M210185en-B | Humidity Calibrator HMK15 User's Guide                     |
| M210297en-C | Hand-held Humidity and Temperature Meter HM70 User's Guide |
| M210316en-A | HMI41 Indicator and HMP41/45/46 Probes Operating Manual    |

## General Safety Considerations

Throughout the manual, important safety considerations are highlighted as follows:

### **WARNING**

Warning alerts you to a serious hazard. If you do not read and follow instructions very carefully at this point, there is a risk of injury or even death.

### **CAUTION**

Caution warns you of a potential hazard. If you do not read and follow instructions carefully at this point, the product could be damaged or important data could be lost.

### **NOTE**

Note highlights important information on using the product.

## Feedback

Vaisala Customer Documentation Team welcomes your comments and suggestions on the quality and usefulness of this publication. If you find errors or have other suggestions for improvement, please indicate the chapter, section, and page number. You can send comments to us by e-mail: [manuals@vaisala.com](mailto:manuals@vaisala.com)

## Product Related Safety Precautions

The Humidity and Temperature Transmitter HMT100 delivered to you has been tested for safety and approved as shipped from the factory. Note the following precautions:

### **CAUTION**

Do not modify the unit. Improper modification can damage the product or lead to malfunction.



## ESD Protection

Electrostatic Discharge (ESD) can cause immediate or latent damage to electronic circuits. Vaisala products are adequately protected against ESD for their intended use. However, it is possible to damage the product by delivering electrostatic discharges when touching, removing, or inserting any objects inside the equipment housing.

To make sure you are not delivering high static voltages yourself:

- Handle ESD sensitive components on a properly grounded and protected ESD workbench. When this is not possible, ground yourself to the equipment chassis before touching the boards. Ground yourself with a wrist strap and a resistive connection cord. When neither of the above is possible, touch a conductive part of the equipment chassis with your other hand before touching the boards.
- Always hold the boards by the edges and avoid touching the component contacts.

## Recycling



Recycle all applicable material.



Dispose of batteries and the unit according to statutory regulations.  
Do not dispose of with regular household refuse.

## Trademarks

HUMICAP is a registered trademark of Vaisala.

## License Agreement

All rights to any software are held by Vaisala or third parties. The customer is allowed to use the software only to the extent that is provided by the applicable supply contract or Software License Agreement.

## Warranty

Vaisala hereby represents and warrants all Products manufactured by Vaisala and sold hereunder to be free from defects in workmanship or material during a period of twelve (12) months from the date of delivery save for products for which a special warranty is given. If any Product proves however to be defective in workmanship or material within the period herein provided Vaisala undertakes to the exclusion of any other remedy to repair or at its own option replace the defective Product or part thereof free of charge and otherwise on the same conditions as for the original Product or part without extension to original warranty time. Defective parts replaced in accordance with this clause shall be placed at the disposal of Vaisala.

Vaisala also warrants the quality of all repair and service works performed by its employees to products sold by it. In case the repair or service works should appear inadequate or faulty and should this cause malfunction or nonfunction of the product to which the service was performed Vaisala shall at its free option either repair or have repaired or replace the product in question. The working hours used by employees of Vaisala for such repair or replacement shall be free of charge to the client. This service warranty shall be valid for a period of six (6) months from the date the service measures were completed.

This warranty is however subject to following conditions:

- a) A substantiated written claim as to any alleged defects shall have been received by Vaisala within thirty (30) days after the defect or fault became known or occurred, and
- b) The allegedly defective Product or part shall, should Vaisala so require, be sent to the works of Vaisala or to such other place as Vaisala may indicate in writing, freight and insurance prepaid and properly packed and labelled, unless Vaisala agrees to inspect and repair the Product or replace it on site.

This warranty does not however apply when the defect has been caused through

- a) normal wear and tear or accident;
- b) misuse or other unsuitable or unauthorized use of the Product or negligence or error in storing, maintaining or in handling the Product or any equipment thereof;
- c) wrong installation or assembly or failure to service the Product or otherwise follow Vaisala's service instructions including any repairs or installation or assembly or service made by unauthorized personnel not approved by Vaisala or replacements with parts not manufactured or supplied by Vaisala;
- d) modifications or changes of the Product as well as any adding to it without Vaisala's prior authorization;
- e) other factors depending on the Customer or a third party.

Notwithstanding the aforesaid Vaisala's liability under this clause shall not apply to any defects arising out of materials, designs or instructions provided by the Customer.

This warranty is expressly in lieu of and excludes all other conditions, warranties and liabilities, express or implied, whether under law, statute or otherwise, including without limitation any implied warranties of merchantability or fitness for a particular purpose and all other obligations and liabilities of Vaisala or its representatives with respect to any defect or deficiency applicable to or resulting directly or indirectly from the Products supplied hereunder, which obligations and liabilities are hereby expressly cancelled and waived. Vaisala's liability shall under no circumstances exceed the invoice price of any Product for which a warranty claim is made, nor shall Vaisala in any circumstances be liable for lost profits or other consequential loss whether direct or indirect or for special damages.

This page intentionally left blank.

## CHAPTER 2

# PRODUCT OVERVIEW

Thank you for choosing the Vaisala HUMICAP® Humidity and Temperature Transmitter Series HMT100. This chapter introduces you to its features.

The Vaisala range of relative humidity measurement instruments covers all the applications from ventilation to process control in demanding explosive areas. For more information about other Vaisala relative humidity instruments, please contact your Vaisala representative or visit [www.vaisala.com](http://www.vaisala.com).

## Introduction to the HMT100 Humidity and Temperature Transmitter

### Product Description

Vaisala HUMICAP® Humidity and Temperature Transmitter Series HMT100 measures relative humidity, temperature and dewpoint. It is powered with a 10 ... 35 VDC or 24 VAC input voltage and it outputs an analog signal of either 4 ... 20 mA, 0 ... 1 V, 0 ... 5 V or 0 ... 10 V.

At order time the HMT100 transmitter can be configured to output either one or two quantities in the following combinations:

- simple RH transmitter
- simple  $T_d$  transmitter
- RH and T transmitter
- $T_d$  and T transmitter

The following accessories are optionally available:

- Wall installation plate (aluminium)
- Duct installation kit
- Rain shield with installation kit
- Rain/solar radiation shield installation kit (for pole installation)

## Fixed and Remote Probe Models

The HMT100 is available either with a fixed probe (0.1 m probe cable) or a remote probe with different cable lengths (3/5/10 m cable lengths, a 10 m extension cable is also available, see Table 12 Options and Accessories on page 48).

The HMP100 relative humidity probe used in the HMT100 transmitter is fully interchangeable. You can easily remove the probe and replace it with a new one without having to adjust the transmitter.

## Optional Display

The HMT100 is also available with an optional one-line display. The display shows the measurement results of selected parameters in selected units (selected at order time). The parameters are displayed in turns one at a time. The display backlight is turned on and off with a jumper on the transmitter electronics motherboard.

## HMT100 Transmitter Components

Figure 1 below illustrates the main features of HMT100. On the left is shown a remote probe model without display and on the right is shown a fixed probe model with the optional display. The numbers and arrows indicate main components of the transmitters.



**Figure 1** HMT100 Components

The following numbers refer to Figure 1 above:

- 1 = Transmitter housing; transmitter cover
- 2 = Probe cover
- 3 = Probe cable
- 4 = HMP100 probe
- 5 = Filter

This page intentionally left blank.



## CHAPTER 3

# INSTALLATION

## Mounting

### Wall Mounting

#### With Plastic Wall Assembly Plate (Provided)

1. Attach the wall assembly plate to the wall with two screws.
2. Press the transmitter down so that it slides down along the rails of the mounting plate.



0505-171

**Figure 2** Plastic Wall Assembly Plate

### With Optional Aluminium Wall Installation Plate

1. Attach the aluminium plate to the wall.
2. Attach the plastic wall assembly plate (provided) to the aluminium plate with two screws.
3. Press the transmitter down so that it slides down along the rails of the wall assembly plate.

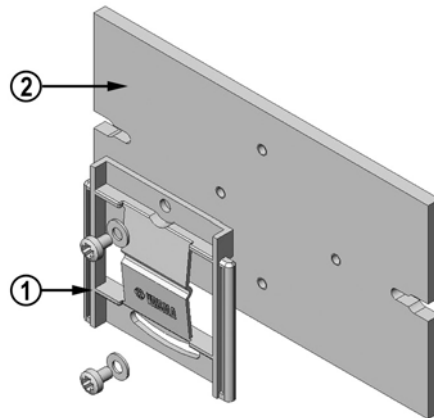

0505-339

**Figure 3 Plastic Wall Assembly Plate with Aluminium Installation Plate**

The following numbers refer to Figure 3 above:

- 1 = Plastic wall assembly plate (provided)
- 2 = Aluminium wall installation plate (optional accessory, see order form)

## Installation with Rain Shield

The rain shield with installation kit includes a metal mounting plate and a rain shield for the transmitter. Vaisala order code: 215109.

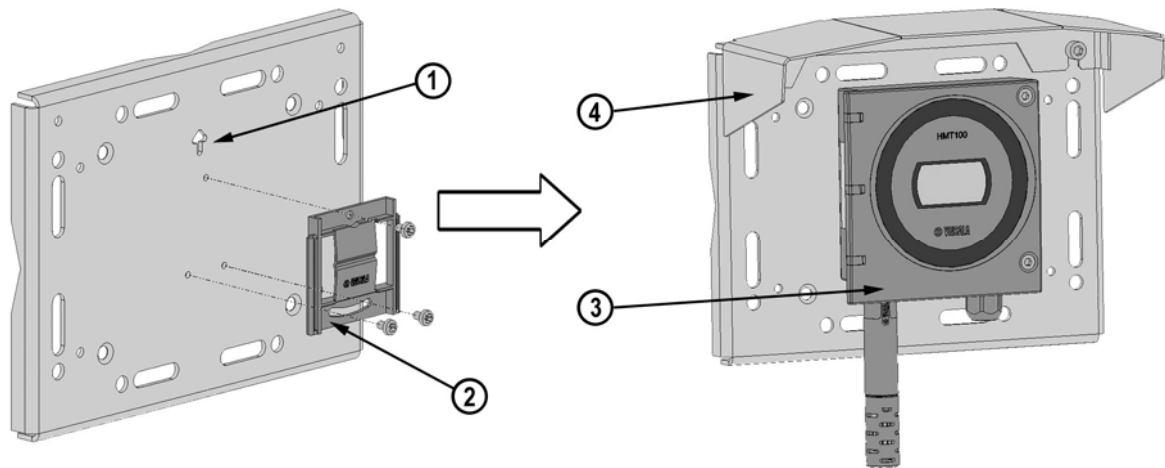

0505-340

**Figure 4 HMT100 Installation with Rain Shield**

1. Fasten the metal mounting plate to the wall or pole with screws (see Figure 4 above). Note the arrow on the mounting plate. Attach the mounting plate with the arrow pointing upwards.
2. Fasten the plastic wall assembly plate (provided) to the metal mounting plate with three screws.
3. Fasten HMT100 Humidity and Temperature Transmitter to the wall assembly plate by pressing the transmitter down so that it slides down along the rails of the mounting plate.
4. Fasten the rain shield to the metal mounting plate with two (M6) mounting screws.

**NOTE**

Remove the rain shield before taking out the HMT100.

## Installation with Radiation Shield

DTR502 with probe installation kit includes a rain/solar radiation shield DTR502 and a plastic installation support for the humidity probe. Vaisala order code: DTR502B. If you already have the DTR502 shield and need only the installation support for the probe, it is available with Vaisala order code: 210623.

1. Fasten the probe to the installation support with two cable ties (items 3 and 4 in Figure 5 below).
2. Insert and attach the support to the radiation shield by tightening the plastic nut (item 2 in Figure 5).
3. Attach the entire radiation shield/probe assembly to a pole mast (pole mast diameter: 30 ... 60 mm/1.2 ... 2.3") with the U-bolt and support arm, see Figure 5.

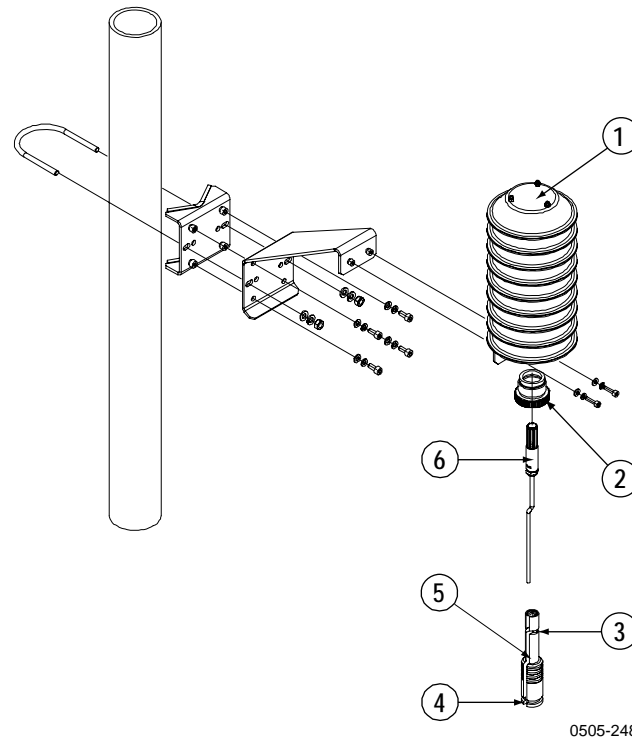

**Figure 5** Installation of the Humidity Probe with the Radiation Shield

The following numbers refer to Figure 5 above:

- 1 = DTR502
- 2 = Plastic nut
- 3, 4 = Cable tie
- 5 = Adapter DRW212054 (installation support)
- 6 = Probe

## Duct Installation Kit

The duct installation kit includes a plastic pipe with a flange. Vaisala order code: 210710. To install the HMP100 probe with the duct installation kit, drill a hole to the duct wall, assemble the probe to the duct installation kit, slide the probe head through the hole, and attach the flange to the duct wall with four screws. See pages 20 and 21 for details.

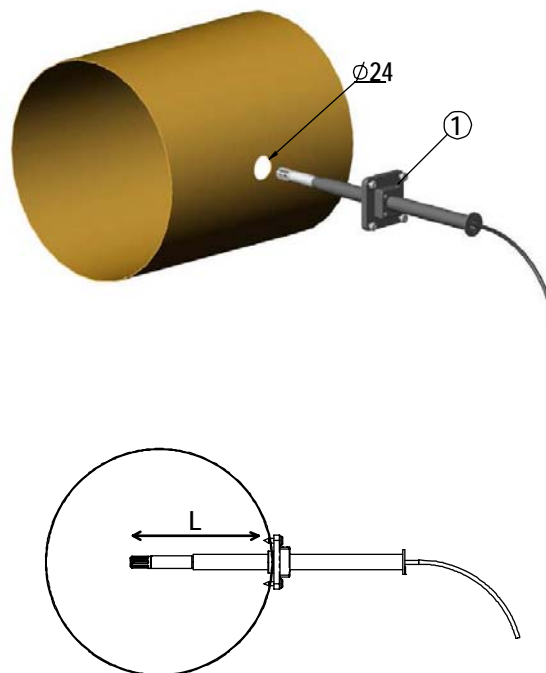

0505-176

**Figure 6** Probe Installation with the Duct Installation Kit

The following explanations refer to Figure 6 above:

1 = Tension screw

Distance L can be adjusted and locked in place with the tension screw.

## Probe Assembly with Duct Installation Kit

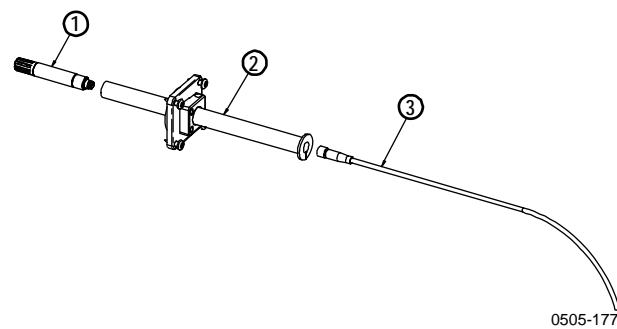

**Figure 7 Assembly of the Humidity Probe with the Duct Installation Kit**

The following numbers refer to Figure 7 above:

- 1 = HMP100
- 2 = Duct installation kit
- 3 = Probe cable

1. Slide the probe cable through the duct installation kit plastic pipe.
2. Attach the probe cable to the HMP100 Humidity Probe.
3. Attach probe assembly to the duct.

## Drilling Instructions for Duct Installation Kit

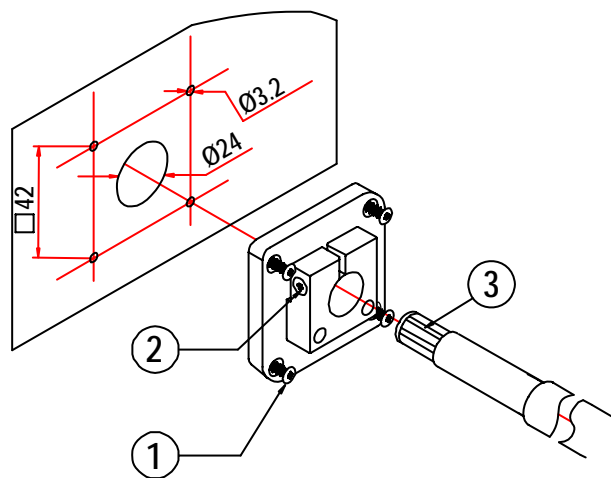

0505-178

**Figure 8 Drilling Instructions**

The following numbers refer to Figure 8 on page 21:

- 1 = Mounting screw
- 2 = Tension screw
- 3 = HMP100 assembled in duct installation kit plastic pipe

Drill the holes for the duct installation kit as follows:

1. Use a 24 mm drill bit to drill a hole to the duct wall for the humidity probe.
2. Drill holes for the duct installation kit mounting screws around the hole in a square arrangement, 42 mm apart from each other. Use a 3.2 mm drill bit to drill the holes for the mounting screws (four ST4.2×16-C-Z DIN 7981 screws).

# Connections

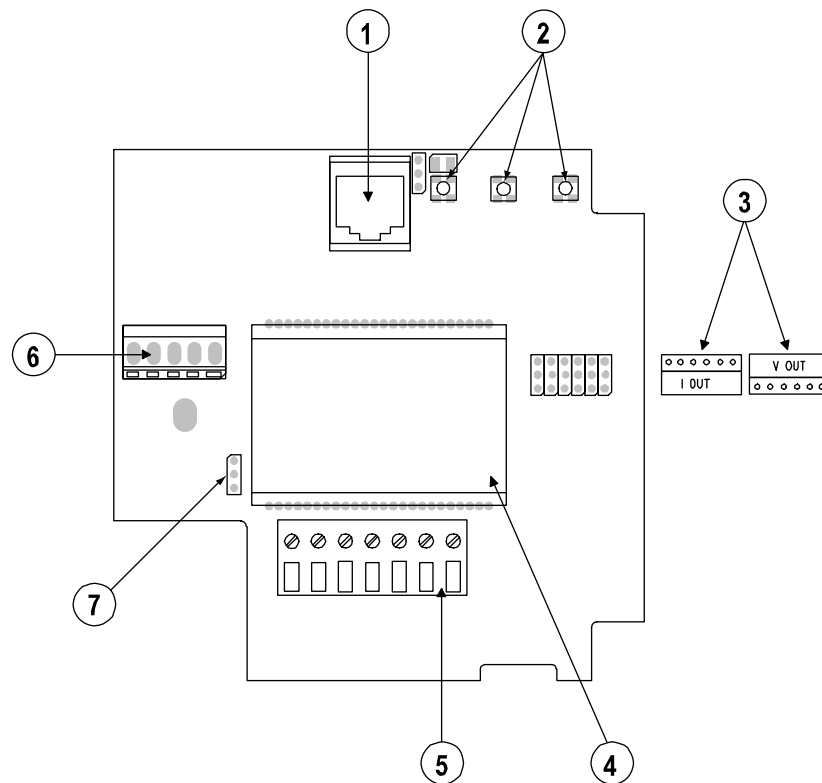

0505-179

**Figure 9 HMT100 Connection Board**

The following numbers refer to Figure 9 above:

- 1 = Service port
- 2 = Adjustment buttons
- 3 = Jumpers
- 4 = Optional LCD
- 5 = Field wire terminals
- 6 = Connector for HMP100 Humidity Probe
- 7 = Display backlight jumper (only in voltage output version); factory setting: backlight ON)

1. Open the transmitter cover by taking out the cover screws.
2. Insert the power supply wires and the signal wires through the cable bushing in the bottom of the transmitter.



3. Connect the wires as indicated in Figure 10 and in Table 3 below. Note that you must wire the transmitter according to the type of transmitter (specified at order time; 2-wire current output or 3-wire voltage output).

**NOTE**

If an isolated output is required with current outputs then both channels require their own power supply. CH1 is always required to be powered (CH1 is the main output and the transmitter will not operate if only CH2 is connected).

4. Close the cover and tighten the cover screws. The transmitter is ready for use.

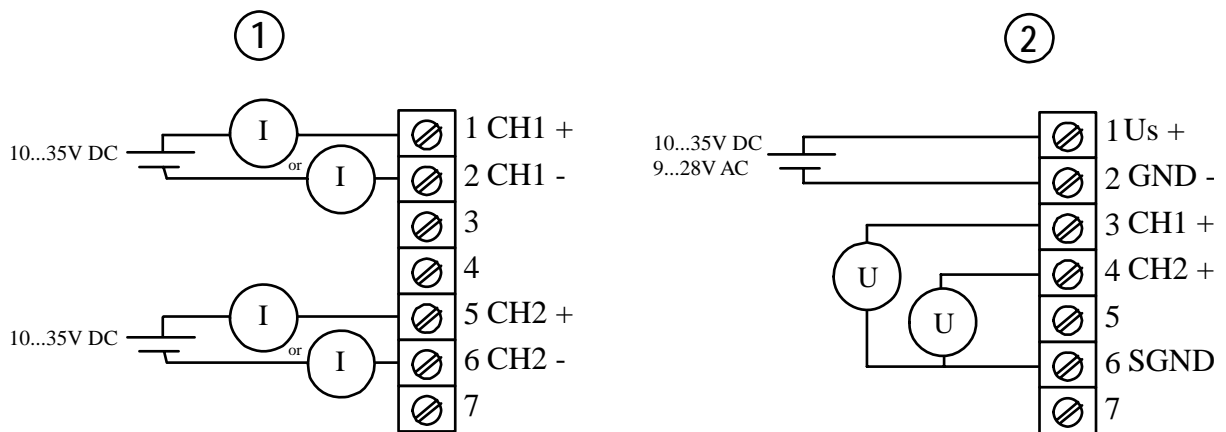

0505-246

**Figure 10** (1) Isolated Current-Loop Wiring, (2) Voltage Output Wiring

**Table 3** Wiring Table

| Terminal | Current Output<br>(2-Wire, CH2 Isolated) | Voltage Output<br>(3-Wire) |
|----------|--|----------------------------|
| 1        | CH1+ (signal and power supply +)         | Power supply +             |
| 2        | CH1- (signal and power supply -)         | Power supply -             |
| 3        |  | CH1+                       |
| 4        |  | CH2+                       |
| 5        | CH2+ (signal and power supply +)         |                            |
| 6        | CH2- (signal and power supply -)         | CH- (for both channels)    |
| 7        | Shield                                   | Shield                     |

The numbers 1 ... 7 in the first column of the wiring table refer to Figure 10 above. If you have at order time selected a two-wire transmitter, make the wiring according to item 1 in Figure 10. If you have selected a three-wire transmitter, make the wiring according to item 2 in Figure 10.

This page intentionally left blank.

## CHAPTER 4

# MAINTENANCE

This chapter provides information that is needed in basic maintenance of the product.

## Replacing the HUMICAP<sup>®</sup> Sensor

### Fixed Probe Model

1. The end of the plastic probe cover is detachable. Carefully turn the end about 1/6 of a turn to loosen it. Remove the end of the probe cover and the filter.
2. Remove the damaged sensor and insert a new one.
3. Recalibrate the transmitter.
4. Replace a dirty filter to ensure a maximum lifetime and a fast response for the sensor. Do not attempt to clean the filter.

### Remote Probe Model

1. Remove the filter (plastic grid or sintered stainless steel).
2. Remove the damaged sensor and insert a new one.
3. Recalibrate the transmitter.
4. Replace a dirty filter to ensure a maximum lifetime and a fast response for the sensor. Do not attempt to clean the filter.

# Removing and Fastening the Probe

## Fixed Probe Model

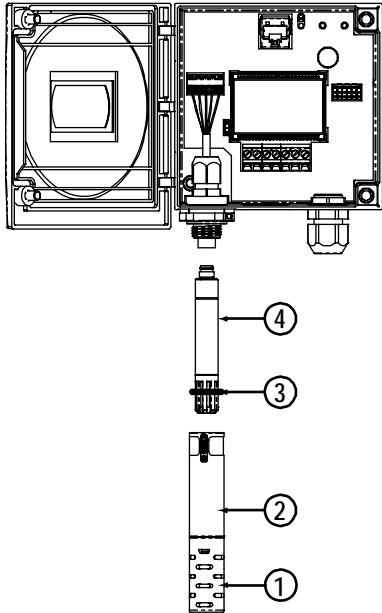

0505-181

Remove and replace the probe as follows:

1. Loosen the plastic probe cover by carefully turning it counter clock wise.
2. Remove the probe cap and O-ring.
3. Remove the probe cover. The probe is now exposed.
4. Unscrew the small sleeve that is securing the probe in place and pull out the probe.
5. Replace the probe and screw back on the small sleeve securing the probe tightly in its place.
6. Replace the probe cover and screw it tightly back in its place.
7. Replace the O-ring and probe cap.

**Figure 11 Removing the Humidity Probe (Fixed Probe Model)**

The following numbers refer to Figure 11 above:

- 1 = Probe cap
- 2 = Probe cover
- 3 = O-ring
- 4 = HMP100 probe

## Remote Probe Model

1. Unscrew the small sleeve that is securing the probe in place at the end of the probe cable and pull out the probe.
2. Replace the probe and screw back on the small sleeve securing the probe tightly in its place.

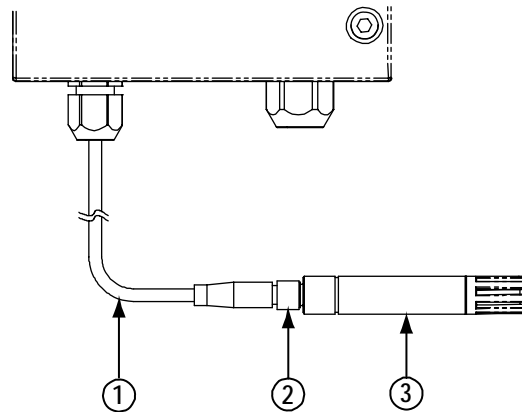

0506-006

**Figure 12 Removing the Humidity Probe (Remote Probe Model)**

The following numbers refer to Figure 12 above:

- 1 = Probe cable
- 2 = Sleeve securing the probe to the cable
- 3 = HMP100 probe

## Calibration and Adjustment

Calibrate and adjust the HMT100 using the push-buttons on the motherboard or with portable humidity meters HM70 or HMI41.

For calibration against saturated salt solutions, a calibrator kit is needed. The HMK15 Humidity Calibrator and pre-measured certified salts are available from Vaisala. For further information please contact your Vaisala representative.

Vaisala Service Centers also offer accredited calibrations for humidity and temperature. See contact information on page 44.

It is also possible to remove the HMP100 probe and replace it with a new one. The old probe can be adjusted using another HMT100 transmitter body, if you have one available.

## Relative Humidity Adjustment Using the Push-Buttons

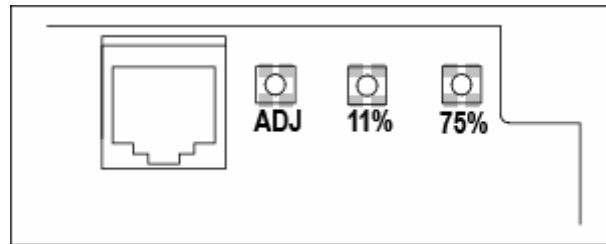

0505-182

**Figure 13** Adjustment Buttons

A simple push-button adjustment is carried out using two relative humidity references: 11.3 % RH (LiCl) and 75.5 % RH (NaCl).

To carry out the adjustment, follow the instructions below:

1. Remove the probe cover and the filter.
2. Open the transmitter cover.
3. Start the adjustment by pressing the ADJ button (on the transmitter electronics motherboard). An indicator led lights up.
4. Insert the probe into the measurement hole of the LiCl salt chamber. The indicator led blinks evenly.

5. Wait for 30 minutes or until the indicator led stops blinking and lits continuously. This means that the measurement has stabilized.
6. Press the LiCl 11 % button to adjust the 11 % condition.
7. Insert the probe into the measurement hole of the NaCl salt chamber. The indicator led starts to blink evenly.
8. Wait for 30 minutes or until the indicator led stops blinking and lits continuously. This means that the measurement is stabilized
9. Press the NaCl 75 % button to adjust the 75 % condition.
10. Now the transmitter returns to normal operation mode and the indicator led is unlit.
11. Replace the filter and the probe cover.

## Adjustment with HM70

You can check and adjust the HMT100 relative humidity measurement with the HM70 Hand-Held Humidity and Temperature meter. A HM70-connection cable is needed, Vaisala order code: 211339.

There are four types of adjustments available: field checking and adjustment using a calibrated reference probe, one-point adjustment using a calibrator, two-point adjustment using a calibrator and LiCl-NaCl adjustment.

Follow the 7 first steps and continue according to the chosen adjustment method.



0505-351

**Figure 14** Location of the MI70 Probe and Cable Connector Ports

1. Connect the 211339 HM70-connection cable to the SERVICE PORT connector on the HMT100 motherboard (see Figure 9 on page 22).
2. Connect the other end of the connection cable to either of the HM70's connector ports located on the bottom of the indicator (see Figure 14 above).
3. Turn on both devices (or just the HM70 if HMT100 is on continuously).
4. The reading of the transmitter is shown on the top or middle row of the indicator display, depending on which connector port the connection cable is connected to.
5. Press the ADJ button on the HMT100 motherboard to open the adjustment mode. The indicator led on the HMT100 motherboard starts flashing.  
  
From now on the adjustment is carried out using the MI70 indicator.
6. Press OK to start adjustment.
7. Check the environment settings if needed. Otherwise press NO. Select RH or T adjustment. Continue according to the directions of the desired adjustment method.

### **Field Checking and Adjustment Using a Calibrated Reference Probe**

Follow steps 1 to 7 on page 29 and continue as follows:

8. Check that the probes are located in equal conditions and wait until the readings have stabilized (may take 30 minutes or more). If you are near the probes, do not breath in their direction.
9. Press ADJUST to continue adjusting.
10. Choose To same as RH<sub>I/II</sub> from the MI70 adjustment menu, press SELECT (MI70 automatically recognizes which port the HMP70 series probe is connected to).
11. Confirm the adjustment by pressing YES.
12. The adjustment is done. Press BACK and EXIT to return to the basic display.
13. Turn off the MI70 and detach the connection cable.



## One-Point Adjustment Using a Calibrator

When adjusting the transmitter in only one reference condition, please take care that the reference condition represents the measuring environment. MI70 indicator is used now only as a terminal for visualizing and setting the transmitter's RH reading.

Follow steps 1 to 7 on page 29 and continue as follows:

8. Remove the filter from the transmitter's probe and insert the probe head into the reference condition.
9. Press ADJUST to continue adjusting.
10. Choose 1-point adjustment from the MI70 adjustment menu, press SELECT.

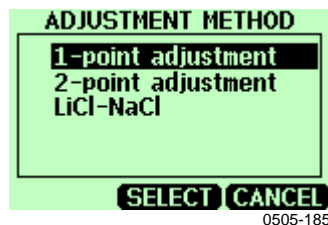

**Figure 15** Example of the MI70 Adjustment Menu

11. Press READY when the reading has stabilized in the reference condition (may take 30 minutes or more). You can follow the stabilization from the GRAPH display.

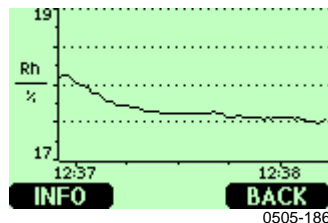

**Figure 16** Example of the MI70 Adjustment Mode Graph Display

12. Enter the correct reference value with the arrow buttons. Press OK.
13. Confirm the adjustment by pressing YES.
14. The adjustment is done. Press BACK and EXIT to return to the basic display.
15. Turn off the MI70 and detach the connection cable.

## Two-Point Adjustment Using a Calibrator

Note that the difference between the two reference humidities must be at least 50 %. MI70 indicator is used now only as a terminal for visualizing and setting the transmitter's RH reading.

Follow steps 1 to 7 (page 29) and continue as follows:

8. Remove the filter from the transmitter's probe and insert the probe head into the lower humidity reference condition.
9. Press ADJUST to continue adjusting.
10. Choose 2-point adjustment from the MI70 adjustment menu, press SELECT.
11. Press READY when the reading has stabilized in the first reference condition (may take 30 minutes or more). You can follow the stabilization from the GRAPH display.
12. Enter the correct reference value in the first condition with the arrow buttons. Press OK.
13. Remove the probe from the first reference conditions and insert the probe head into the higher humidity reference condition.
14. Press READY when the reading has stabilized in the second reference condition (may take 30 minutes or more). You can follow the stabilization from the GRAPH display.
15. Enter the correct reference value in the second condition with the arrow buttons. Press OK.
16. Confirm the adjustment by pressing YES (by pressing NO you return to adjustment mode display and no changes are made). If the difference between the two reference conditions is less than 50 %RH, adjustment can not be done.
17. The adjustment is done. Press BACK and EXIT to return to the basic display.
18. Turn off the MI70 and detach the connection cable.

## LiCl-NaCl Adjustment

This adjustment is done using relative humidity references 11.3 % RH (LiCl) and 75.5 % RH (NaCl).

Follow steps 1 to 7 (page 29) and continue as follows:

8. Remove the filter from the transmitter's probe and insert the probe head into the LiCl salt chamber.
9. Press ADJUST to continue adjusting.
10. Choose LiCl-NaCl autom. from the MI70 adjustment menu, press SELECT. Press OK to accept the note telling about references.
11. Press READY when the reading has stabilized in the LiCl salt chamber (may take 30 minutes or more). You can follow the stabilization from the GRAPH display.
12. Remove probe from the LiCl salt chamber and insert the probe head into the NaCl salt chamber.
13. Press READY when the reading has stabilized in the NaCl salt chamber (may take 30 minutes or more). You can follow the stabilization from the GRAPH display.
14. Confirm the adjustment by pressing YES (by pressing NO you return to adjustment mode display and no changes are made).
15. The adjustment is done. Press BACK and EXIT to return to the basic display.
16. Turn off the MI70 and detach the connection cable.

## Temperature Field Check and Adjustment by Using a Calibrated Reference Probe

Follow steps 1 to 7 (page 29) and continue as follows:

8. Check that the probes are located in equal conditions and wait until the readings are stabilized (can take 30 minutes or more). If you are near the probes, do not breathe in their direction.
9. Press ADJUST to continue adjusting.
10. Press To same as  $T_{H/L}$ , press SELECT. (MI70 recognizes always the port to which the HMP70 series probe is connected).
11. Confirm by pressing YES.

|             |   |
|-------------|---|
| <b>NOTE</b> | If the temperature difference between the reference probe and HMT100 is too large, the adjustment cannot be done (HM70 will notify you of this). The available reserve for T adjustment of HMT100 depends on the initial temperature calibration of the unit. |
|-------------|---|

12. Adjustment is done. Press BACK and EXIT to return to the basic display.
13. Switch off the MI70 and detach the calibration cable from MI70 and from the transmitter.

## Adjustment with HMI41

You can check and adjust the HMT100 relative humidity measurement with the HMI41 indicator and HMP41/45/46 probes. A HMI41-connection cable is needed, Vaisala order code: 25917ZZ.

There are three adjustment modes available: offset (dry point), gain (wet point), and two-point adjustment. All of these can be performed using the HMI41 either as a reference meter (for example when the transmitter is mounted in an air-conditioning channel) or only as a terminal for visualizing and setting the transmitter's RH reading.

Offset and gain adjustments are performed the same way and differ only in internal calculations. Select offset adjustment when the reference humidity is  $< 65\%$  RH and gain adjustment when the reference humidity is  $\geq 65\%$  RH. Two-point adjustment is more accurate, and includes both offset and gain corrections. For performing two-point adjustment, you need two separate measurement points with a difference of at least  $50\%$  RH between them.

Follow the general directions of connecting the HMI41 to the HMT100 and selecting the HMI41 calibrator function and then continue according to the chosen adjustment method.

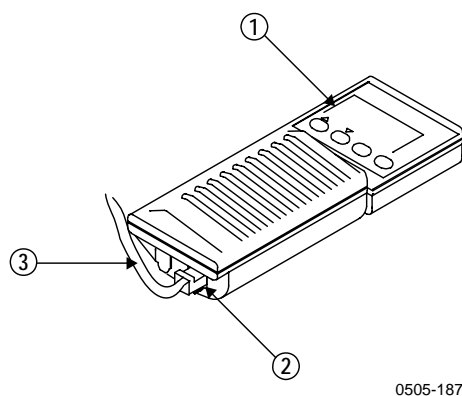

**Figure 17** Location of the HMI41 Calibration Connector

The following numbers refer to Figure 17 above:

- 1 = HMI41 indicator
- 2 = EXT connector
- 3 = 25917ZZ connection cable

## Connections and Selecting the Calibrator Function

1. To select the calibrator function from the HMI41, press ON/OFF button until you can see some text on the display. Then release the ON/OFF button and within 1 ... 2 seconds, press both ENTER and MODE buttons until the following display appears:



2. After a few seconds, the display changes to show the following:

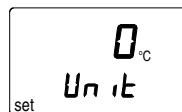

If the basic settings (display units, automatic power off function, display quantities, and pressure) have to be changed, please refer to the HMI41 Operating Manual. Otherwise, press ENTER repeatedly until the following display appears:



To calibrate the HMT100, select number 3 with buttons ▲ (number up) and ▼ (number down) and then press ENTER.

3. Next the baud rate appears on the display. Use the baud rate 19200 (= 19.2 on the HMI41 display) with the HMT100 series. If the baud rate on the HMI41 display is not correct, change it with buttons ▲ and ▼. When the baud rate is correct, press ENTER, and the serial communications settings display appears. The correct settings for HMT100 series are: N, 8, 1. If needed, change the settings with buttons ▲ and ▼ until they are correct, press ENTER, and then ON/OFF.

These settings are stored in the HMI41 memory; when the HMI41 is turned on again, it will automatically wake up as a calibrator for digital transmitters with these serial line settings. After making these settings, continue with the adjustment and follow the directions of the chosen adjustment method.

## Offset and Gain Adjustments

Offset and gain adjustments are performed in the same way (they differ only in internal calculations) so the following chapter is valid for both methods.

4. Connect the 25917ZZ HMI41-connection cable to the SERVICE PORT connector on the HMT100 motherboard (see Figure 9 on page 22).
5. Connect the other end of the connection cable to the EXT connector located on the bottom of the HMI41 indicator (see Figure 17 on page 35).
6. Turn on both devices. Wait until the following display appears:



A rectangular display box with a thin border. In the top-left corner, there is a small 'RH' label. The main text is 'CAL' on the top line and 'OFFSE' on the bottom line, both in a large, bold, monospace font.

7. Select the appropriate adjustment mode with the ▲ and ▼ buttons. Select offset adjustment if the humidity is < 65 %RH and gain adjustment if the humidity is ≥ 65 %RH:

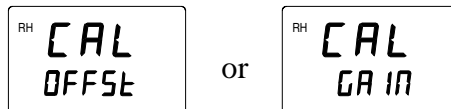

Two rectangular display boxes with thin borders, separated by the word 'OR'. The left box shows 'RH CAL OFFSE' and the right box shows 'RH CAL GA IN'. Both are in a large, bold, monospace font.

Press ENTER to confirm the selection. A display similar to the following appears:

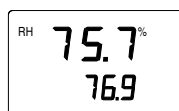

A rectangular display box with a thin border. In the top-left corner, there is a small 'RH' label. The main text is '75.7%' on the top line and '76.9' on the bottom line, both in a large, bold, monospace font.

The next sections describe how to perform offset and gain adjustments in two different ways.

### HMI41 as a Reference Meter

The HMI41 humidity probe is used to show the correct humidity value (be sure that the reference probe has previously been adjusted). Connect the cable and select the appropriate adjustment method as previously explained and continue according to the following instructions.

8. A display similar to the one below should be visible:



Numbers on the first line indicate the transmitter reading, and the numbers on the second line indicate the reference probe reading.

9. Let the readings stabilize (may take 30 minutes or more). If you prefer, you can change the display to show the difference in the readings. Press HOLD and a display similar to the following appears:

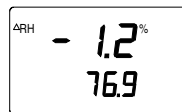

The numbers on the first line indicate how much the transmitter reading differs from that of the HMI41 reference probe. The numbers on the second line indicate the reference probe reading. You can return to the previous display by pressing HOLD again.

10. When the readings have stabilized, press ENTER to conclude the adjustment. When ENTER is pressed, the transmitter reading is corrected to the reference probe reading. If the adjustment has been successful, the following display appears:



11. The data is now stored in the transmitter memory. If the adjustment has not been successful, the following display appears:





12. In this case, perform the adjustment again. Whether the adjustment was successful or not, the HMI41 always returns to display the selected adjustment mode.
13. After successfully completing the adjustment, turn off the HMI41 and disconnect the cable.

### HMI41 as a Terminal

The HMI41 can also be used for visualizing and setting the transmitter's RH reading manually.

8. A display similar to the one below should be visible:

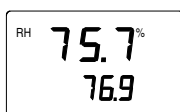

The numbers on the first line indicate the transmitter reading, and the numbers on the second line indicate the HMI41 probe reading.

9. Let the readings stabilize and press MODE. The following display appears:



The HMI41 now works only as a terminal for setting the humidity reading. The numbers on the first line are blinking, and the numbers on the second line indicate the transmitter reading.

10. You can now set the blinking reading to the correct value (for example, the equilibrium RH of a salt solution) with the buttons ▲ and ▼. Press ENTER to conclude the adjustment. If the adjustment has been successful, the following display appears:



11. The data is now stored in the transmitter memory. If the adjustment has not been successful, the following display appears:





12. In this case, perform the adjustment again. Whether the adjustment was successful or not, the HMI41 always returns to display the selected adjustment mode.
13. After successfully completing the adjustment, turn off the HMI41 and disconnect the cable.

## Troubleshooting

Table 4 presents a summary of a few error messages that may appear during adjustment with the HMI41.

**Table 4 Common Problems During Adjustment and Their Remedies**

| Error Message   | Probable Cause   | Remedy   |
|---|--|--|
|    | This message may appear for example if the difference between the reference humidities is too small (< 50 %RH).                | Perform the adjustment again.  |
|  | This message may appear during adjustment when the HMI41 is trying to contact the transmitter.                                 | Wait.  |
|  | The connection cable is not properly connected or the serial line settings of the HMI41 and the transmitter do not correspond. | Check the connection of the calibration cable. Check that the serial line settings in the HMI41 memory correspond to those of the transmitter. |

## Analog Output Tests

HMT100 has a built-in software function for testing the analog outputs. To test the outputs, do the following:

1. Make sure the transmitter is not in adjustment mode.
2. Press the 75 % adjustment button (see Figure 13 on page 28).

This sets the output current/voltage level to the middle point of the selected output range (specified when ordering the product). The output stays at this level for about 30 seconds after pressing the 75 % adjustment button.

### Examples:

If you have specified 4 ... 20 mA analog output range, pressing the 75 % adjustment button will set the current output at 12.0 mA for about 30 seconds.

For analog output range 0 ... 1 V, pressing the 75 % adjustment button will set the voltage output at 0.5 V for about 30 seconds.

This page intentionally left blank.

## CHAPTER 5

# TROUBLESHOOTING

This chapter describes error messages and provides contact information for Technical Support and Vaisala Service Centers.

## Error Mode

### Current Output

In error mode the analog outputs switch to  $I_{OUT} = 23 \text{ mA}$ . Error mode indication covers only transmitter body electronic functions. The transmitter cannot indicate a faulty RH probe.

### Voltage Output

Voltage output version has no error mode indication.

## Technical Support

For technical questions, contact the Vaisala technical support:

E-mail [helpdesk@vaisala.com](mailto:helpdesk@vaisala.com)

Fax +358 9 8949 2790

## Return Instructions

If the product needs repair, please follow the instructions below to enable us to serve you better.

1. Read the warranty information.
2. Write a Problem Report with the.
3. Please include with the transmitter:
  - Serial number of the unit
  - Date and place of purchase or last calibration
  - Description of the fault
  - Circumstances over which the fault occurred
  - Name and contact information of a technically competent person who can provide further information on the problem
  - A detailed return address with your preferred shipping method
4. Pack the faulty product using an ESD protection bag of good quality with proper cushioning material in a strong box of adequate size.
5. Contact the Vaisala Service Center in your region and send the box to the addresses below:

## Vaisala Service Centers

### **NORTH AMERICAN SERVICE CENTER**

**Vaisala Inc.**, 10-D Gill Street, Woburn, MA 01801-1068, USA.

Phone: +1 781 933 4500, Fax: +1 781 933 8029

E-mail: [us-customersupport@vaisala.com](mailto:us-customersupport@vaisala.com)

### **EUROPEAN SERVICE CENTER**

**Vaisala Instruments Service**, Vanha Nurmijärventie 21 FIN-01670 Vantaa, FINLAND.

Phone: +358 9 8949 2658, Fax: +358 9 8949 2295

E-mail: [instruments.service@vaisala.com](mailto:instruments.service@vaisala.com)

### **TOKYO SERVICE CENTER**

**Vaisala KK**, 42 Kagurazaka 6-Chome, Shinjuku-Ku, Tokyo 162-0825, JAPAN.

Phone: +81 3 3266 9617, Fax: +81 3 3266 9655

E-mail: [aftersales.asia@vaisala.com](mailto:aftersales.asia@vaisala.com)

### **BEIJING SERVICE CENTER**

**Vaisala China Ltd.**, Floor 2 EAS Building, No. 21 Xiao Yun Road, Dongsanhuan Beilu, Chaoyang District, Beijing, P.R. CHINA 100027.

Phone: +86 10 8526 1199, Fax: +86 10 8526 1155

E-mail: [china.service@vaisala.com](mailto:china.service@vaisala.com)

**[www.vaisala.com](http://www.vaisala.com)**

## CHAPTER 6

# TECHNICAL DATA

This chapter provides the technical data of the product.

## Specifications

**Table 5 Relative Humidity Measurement Specifications**

| Property  | Description / Value  |
|---|--|
| Measurement range   | 0 ... 100 %RH  |
| Accuracy against factory standards including non-linearity, hysteresis, and repeatability<br>at +15 ... +25 °C<br><br>at 0 ... +40 °C<br>at -40 ... 0 °C and +40 ... +80 °C | ±1.7 %RH (0 ... 90 %RH)<br>±2.5 %RH (90 ... 100 %RH)<br>±(1.7 + 0.015 × reading) %RH<br>±(2.0 + 0.025 × reading) %RH |
| Factory calibration uncertainty at 20 °C (68 °F)  | ±1.0 %RH (0 ... 15 %RH)<br>±1.5 %RH (15 ... 78 %RH)  |
| Response time (90 %) at 20 °C in still air  | 8 s with plastic grid<br>20 s with membrane filter<br>40 s with sintered filter                                      |
| Humidity sensor   | HUMICAP <sup>®</sup> 180   |

**Table 6 Temperature Measurement Specifications**

| Property                    | Description / Value                |
|-----------------------------|------------------------------------|
| Measurement range           | -40 ... +80 °C (-40 ... 176 °F)    |
| Accuracy at +20 °C (+68 °F) | ±0.2 °C (See Figure 18 on page 46) |
| Temperature sensor          | Pt1000 IEC 751 ½ class B           |

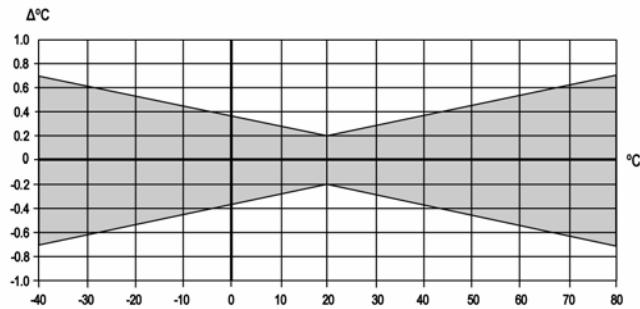

0505-247

**Figure 18 Accuracy of Temperature Measurement**

**Table 7 Dewpoint Temperature (Calculated) Measurement Specifications**

| Property        | Description / Value            |
|-----------------|--------------------------------|
| Measuring range | -20 ... +80 °C (+4 ... 176 °F) |
| Accuracy        | see Table 8 below              |

**Table 8 Accuracy of Dewpoint Temperature Measurement**

| Temp. | Relative humidity |     |     |     |     |     |     |     |     |     |
|-------|-------------------|-----|-----|-----|-----|-----|-----|-----|-----|-----|
|       | 10                | 20  | 30  | 40  | 50  | 60  | 70  | 80  | 90  | 100 |
| -20   | 2.6               | 1.7 | 1.4 | 1.2 | 1.1 | 1.1 | 1.0 | 1.0 |     |     |
| -10   | 2.7               | 1.7 | 1.3 | 1.2 | 1.1 | 1.0 | 1.0 | 1.0 | 0.9 |     |
| 0     | 2.3               | 1.4 | 1.1 | 1.0 | 0.9 | 0.8 | 0.8 | 0.8 | 0.7 | 0.7 |
| 10    | 2.3               | 1.4 | 1.1 | 0.9 | 0.8 | 0.9 | 0.8 | 0.8 | 0.8 | 0.8 |
| 20    | 2.2               | 1.2 | 1.0 | 0.8 | 0.7 | 0.6 | 0.6 | 0.5 | 0.5 | 0.6 |
| 40    | 3.0               | 1.9 | 1.5 | 1.3 | 1.2 | 1.1 | 1.0 | 1.0 | 1.0 | 1.0 |
| 60    | 4.3               | 2.7 | 2.2 | 1.9 | 1.8 | 1.7 | 1.6 | 1.5 | 1.5 | 1.5 |
| 80    | 4.9               | 3.1 | 2.5 | 2.2 | 2.1 | 2.0 | 1.9 | 1.8 | 1.8 | 1.8 |

**Table 9 Operating Environment Specifications**

| Property                       | Description / Value                                      |
|--------------------------------|--|
| Operating temperature range    |  |
| Transmitter body, no display   | -40 ... +60 °C (-40 ... +140 °F)                         |
| Transmitter body, with display | -30 ... +60 °C (-22 ... +140 °F)                         |
| Sensor head                    | -40 ... +80 °C (-40 ... +176 °F)                         |
| Storage temperature range      | -40 ... +60 °C (-40 ... +140 °F)                         |
| Electromagnetic compatibility  | EN61326-1:1997+Am1:1998; + Am2:2001; Generic Environment |



**Table 10 Inputs and Outputs**

| Property  | Description / Value  |
|---|--|
| <b>Current output version</b><br>Two-wire output signal<br>External loop load with 4 ... 20 mA  | 4 ... 20 mA (loop powered)<br>10 ... 35 VDC ( $R_L = 0$ ohms)<br>20 ... 35 VDC ( $R_L = 500$ ohms)   |
| <b>Voltage output version</b><br><br>Supply voltage<br><br>Current consumption,<br>35 VDC/24 VAC<br>Voltage output signals<br><br>External load with voltage output | <br><br>10 ... 35 VDC, 24 VAC<br><br>max 12 mA<br><br>0 ... 1 V, 0 ... 5 V, 0 ... 10 V,<br>0 ... X V, see order form<br><br>$R_L$ min. 10 k $\Omega$ |

**Table 11 Mechanics Specifications**

| Property  | Description / Value / Order Code                             |
|---|--|
| Material<br>Housing<br>Probe<br>Mounting plate GM45160  | ABS/PC plastic<br>chrome coated aluminium<br>ABS plastic     |
| Housing classification  | IP65 (NEMA 4)  |
| Sensor protection<br>Plastic grid<br>Plastic grid with membrane filter<br>Sintered stainless steel filter | DRW010522<br>DRW010525<br>HM46670SP                          |
| Connections   | screw terminals 0.5 ... 1.5 mm <sup>2</sup>                  |
| Probe cable lengths   | 3 m, 5 m, 10 m<br>10 m extension available                   |
| Display (optional)  | one line with changing (at 6 s intervals) or fixed variables |

**Table 12 Options and Accessories**

| <b>Description</b>                | <b>Order Code</b> |
|-----------------------------------|-------------------|
| Sensor head HMP100                | HMP100            |
| Humidity sensor                   | Humicap180        |
| T-sensor PT1000                   | 18921             |
| Filter plastic grid + membrane    | DRW010525         |
| Sintered stainless steel filter   | HM46670SP         |
| Extension cable 10m               | DRW220095         |
| Probe cable 0.1 m                 | HMP50Z010SP       |
| Probe cable 3m                    | HMP50Z300SP       |
| Probe cable 5m                    | HMP50Z500SP       |
| Probe cable 10m                   | HMP50Z1000SP      |
| Radiation shield                  | DTR502B           |
| Rain shield with installation kit | 215109            |
| Probe holder                      | 215986            |
| Duct installation kit             | 215619            |
| Wall assembly plate (plastic)     | GM45160           |
| Installation plate (aluminium)    | DRW010712         |
| Probe cap                         | HM47329           |
| Casing for probe                  | HM47328           |
| HMI41 connection cable            | 25917ZZ           |
| HM70 connection cable             | 211339            |



## Dimensions in mm (inches)

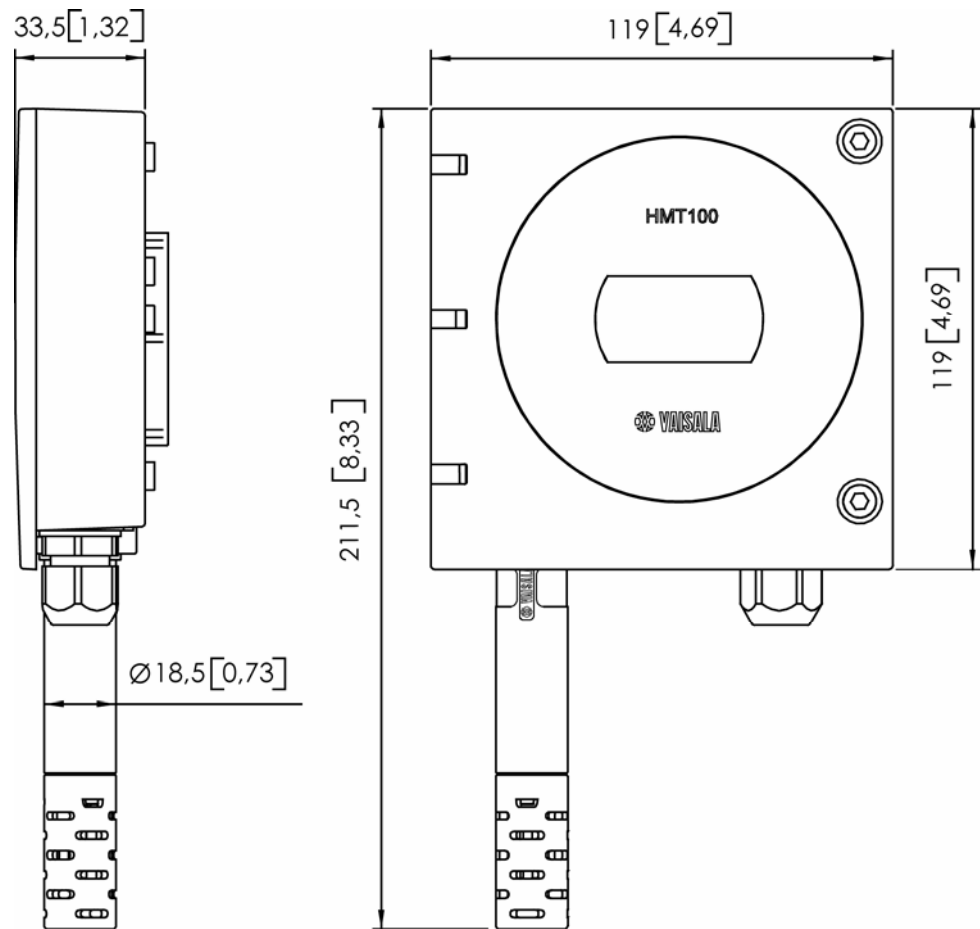

0505-188

**Figure 19** Dimensions HMT100 Fixed Probe Model

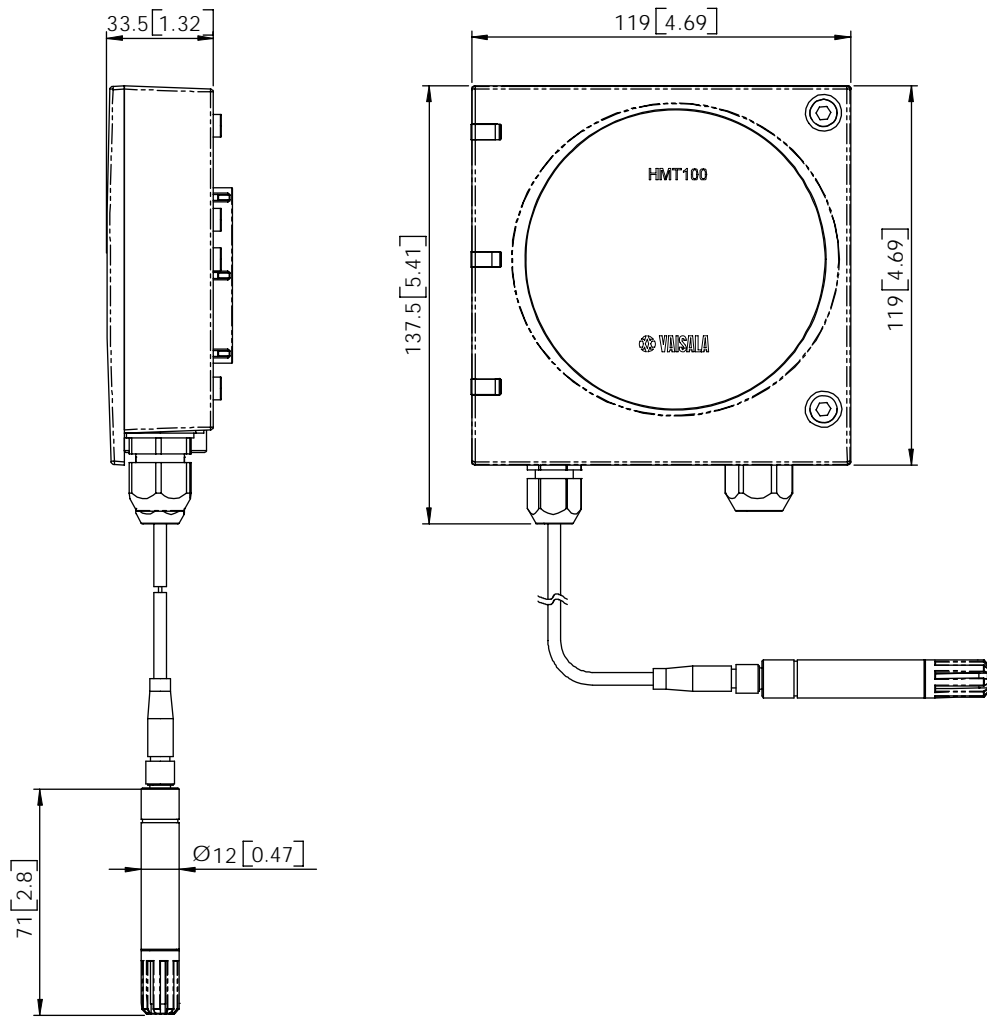

0505-189

**Figure 20**      **Dimensions HMT100 Remote Probe Model**





[www.vaisala.com](http://www.vaisala.com)