

EQ09-A & EQ09-AE PYRANOMETER

(upgrade of EQ08-S & EQ08-SE Secondary Standard Pyranometer)

ISO Spectrally Flat Pyranometer of Class A for Solar GHI measurement



The Middleton EQ09-A is a precision Pyranometer for measuring solar Global Horizontal Irradiance (GHI). It exceeds the International Organization for Standardization (ISO) specifications for a **Spectrally Flat Pyranometer of Class A**. Class A is the highest accuracy Class. The EQ09-A incorporates a unique thermoelectric sensor that has exceptionally low directional error without compromise to signal strength or response time. The EQ09-AE version has an in-built amplifier to give a millivolt output for easy signal measurement.

Performance Specification	ISO 9060:2018 ¹ Spectrally Flat Class A ²	EQ09-A & EQ09-AE
Response time (to 95%)	< 10 sec	8 ±1 sec
Zero off-set a) -200 W.m ⁻² thermal rad.	± 7 W.m ⁻²	< 3 W.m ⁻² (unventilated)
Zero off-set b) 5 K.h ⁻¹ ambient temp.	± 2 W.m ⁻²	< ± 1.5 W.m ⁻²
Zero off-set c) total response	± 10 W.m ⁻²	< ± 5 W.m ⁻²
Non-stability (1 year interval)	± 0.8 %	< ± 0.5 %
Non-linearity (100-1000 W.m ⁻²)	± 0.5 %	< ± 0.5 %
Directional response (w.r.t. 1000 W.m ⁻²) ³	± 10 W.m ⁻²	< ± 10 W.m ⁻²
Spectral error (280 to 4,000 nm)	± 0.5 W.m ⁻²	< ± 0.4 W.m ⁻²
Spectral selectivity (350 to 1,500 nm) ⁴	< 3 %	< 3 %
Temperature response (-10 to +40 °C)	± 1 %	< ± 1 %
Tilt response (0-90°)	± 0.5 %	< ± 0.2 %
Additional signal processing errors	± 2 W.m ⁻²	EQ09-A, not applicable EQ09-AE < ± 2 W.m ⁻²

¹ ISO 9060:2018 Specification and classification of instruments for measuring hemispherical solar and direct solar radiation

² ISO 9060:2018 'Class A' roughly corresponds to superseded ISO 9060:1990 'Secondary Standard'

³ ISO 9060:2018 requires that a 'Class A' pyrheliometer be individually tested for Directional & Temperature Response

⁴ This requirement designates a Pyranometer as 'spectrally flat' in ISO 9060:2018

Middleton Solar EQ09-A & EQ09-AE Pyranometer Detailed Specification

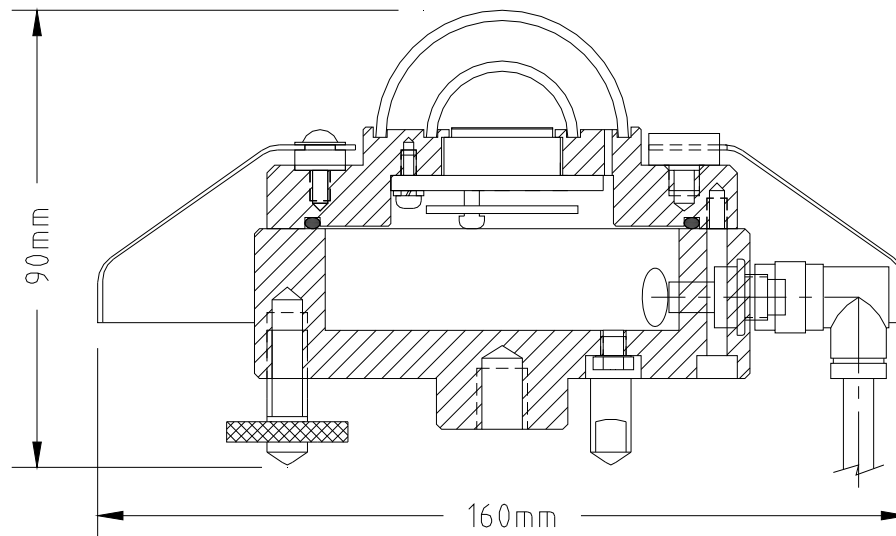

Black carbon nanotube (CNT) sensor surface has flat spectral response, excellent stability, and low directional error.
The EQ09-A has a passive microvolt output, and the EQ09-AE version has an in-built signal amplifier.
Dual glass domes protect the sensor from air temperature fluctuations.
User's Guide and Calibration Certificate included.

General Specification

viewing angle	2π steradians
irradiance	0 – 4,000 W/m ²
spectral range	300 - 3000nm (nominal); 305 – 2,700nm (50% points)
sensitivity (typical)	EQ09-A: $17 \pm 1 \mu\text{V}/\text{W}\cdot\text{m}^{-2}$; EQ09-AE: 1.0 mV/W.m ⁻²
calibration	outdoors to ISO 9847, traceable to WRR
achievable uncertainty (minute totals)	$U_{95} = 2\%$ (RSS of instrument, calibration, measurement)
operating temperature	-40 to +80°C
operating humidity	0-100% RH
output impedance	20 Ω (EQ09-A); 65 Ω (EQ09-AE)
measurement input impedance	>1 M Ω
power requirement (EQ09-AE only)	5 to 15 VDC, 6mA
bubble level resolution	0.1°
level adjustment	one fixed foot, two adjustable feet
construction	anodised marine-grade aluminium & stainless steel
desiccant	orange silica gel (non-toxic)
IP rating	sealed to IP67
mounting method	central M10 hole in base (mounting fastener included)
output lead	6m, with connector at instrument end
net weight	0.8Kg (excluding lead)
shipping size & weight	230 x 230 x 180mm, 2Kg
warranty	2 years (standard) / 5 years (conditional)

Available Options

- temperature output (EQ09-A only), YSI 44031 thermistor (10K Ω @ 25°C)
- additional output lead length, up to 20m
- EV2-H Ventilator / Heater Unit
- EQ09-A & EQ09-AE Secondary Standard Pyranometer (no directional & temperature test)
- EQ09-AQ version, with fused silica “quartz” domes
- EQ09-AR version, with sensitivity of 7-10 $\mu\text{V}/\text{W}\cdot\text{m}^{-2}$, output impedance 9 Ω
- EQ18-A Pyrano-albedometer, dual head version of EQ09-A