



Mobile Detector MD30



Features

- Compact, multi-parameter mobile sensor
- Designed for snow plow trucks, suitable for any vehicle
- Proven DSC technology optimized for mobile measurements
- Simultaneous water, ice, and snow layer reporting
- Molded design to withstand heavy vibration and water ingress
- Patent pending double-hood for window protection
- Hand-removable hood for easy window cleaning

Vaisala Mobile Detector MD30 is a mobile road condition sensor for winter maintenance operations. The compact MD30 measures all key road weather parameters and is suitable for snow plow trucks and other vehicles. MD30 data is targeted to enable more accurate maintenance decision-making and salt usage optimization.

Measurements

- Grip
- Surface state
- Surface layer thickness
- Surface temperature
- Air temperature
- Dew point and frost point
- Relative humidity

Reliable in Any Weather

To provide quick response time and high sensitivity in road condition reporting, MD30 utilizes an improved, fast-measuring version of the proven DSC laser technology. In cases where external heat sources could disturb the temperature measurements, the road and air temperature sensors can be separated from the MD30 body and placed in desired locations.

Robust for Any Vehicle

The rugged design allows MD30 to operate in snow plow trucks and other vehicles. The core is molded to withstand continuous vibration and to prevent water ingress. Further, the hood has a special vented double structure that directs air flow to protect the window from dirt and splashes.

Easy to Use and Maintain

MD30 provides simplicity for both use and maintenance. It starts to measure automatically when the vehicle starts, and constantly monitors the sensor status. The window is heated to avoid dew and frost formation. When cleaning is needed, the window can be accessed by simply removing the hood by hand, without any tools.

Compact and Cost-effective

MD30 provides grip, as well as other key measurements in one package. The cost-effective product allows you to use the full potential of your vehicle fleet as a data collection platform.

Compact and Cost-effective

MD30 provides grip, as well as other key measurements in one package. The cost-effective product allows you to use the full potential of your vehicle fleet as a data collection platform.

Output and Visualization

MD30 outputs a binary data message over an RS-232 interface, which can also be turned wireless with an external Bluetooth module.

The recommended data collection and visualization platform for MD30 is Vaisala RoadAI, which includes a local Android phone app and an online map interface. The online map can be embedded to Vaisala RoadDSS® Navigator. The phone app can also be set to record video or take photos, to create a powerful combination of sensor data, images and video, and a color-coded map.

Technical Data

Measurement Specifications

Grip and Surface State

Reported level of grip	0.09 ... 0.82
Reported surface states	Dry, moist, wet, ice, snow, slush
Measurement interval	40 times/s

Surface Layer Thickness

Water	0 ... 5 mm (0 ... 0.20 in)
Ice	0 ... 2 mm (0 ... 0.08 in)
Snow (water equivalent)	0 ... 1 mm (0 ... 0.039 in)

Surface Temperature

Measurement range	-40 ... +60 °C (-40 ... +140 °F)
-------------------	----------------------------------

Air Temperature and Relative Humidity

Humidity range	0 ... 100 %RH
Temperature range	-40 ... +60 °C (-40 ... +140 °F)
Dew point range	-40 ... +60 °C (-40 ... +140 °F)

Operating Environment

Operating temperature ¹⁾	-40 ... +60 °C (-40 ... +140 °F)
Storage temperature	-40 ... +60 °C (-40 ... +140 °F)
Operating humidity	0 ... 100 %RH

¹⁾ In the range of +35 ... 60 °C (+95 ... 140 °F), surface layer thickness measurement performance may be degraded.

Inputs and Outputs

Powering	12 ... 32 VDC
Power consumption, maximum	15 W
Protocol	RS-232
Protocol, with optional Bluetooth module	RS-232-to-Bluetooth
Data output	Binary

Compliance

IP rating	IP68
EMC (industrial environment)	EN 61326-1
Vibration	IEC 60068-2-64
Shock	IEC 60068-2-27
Corrosion and salt testing	VDA 621-415
Environmental	IEC 60068-2-1, 2, 14, 30
Eye safety	EN/IEC 60825-1, Laser Class 1

Mechanical Specifications

Weight, mobile sensor with bracket	1.7 kg (3.7 lb)
Installation height, mobile sensor	20 ... 110 cm (7.87 ... 43.31 in)

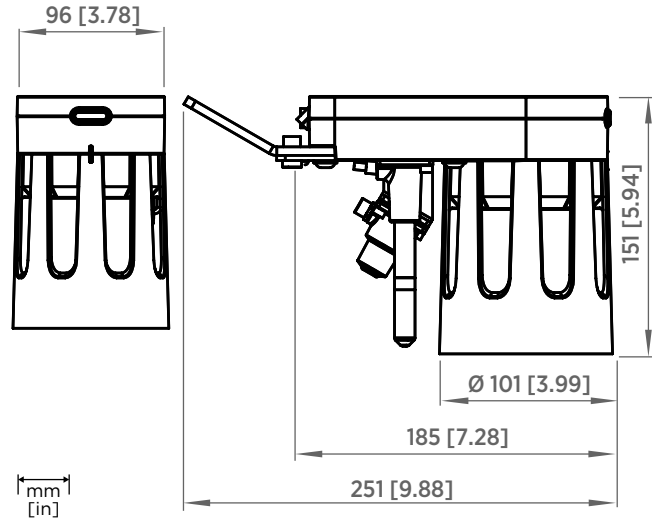

Mobile sensor dimensions

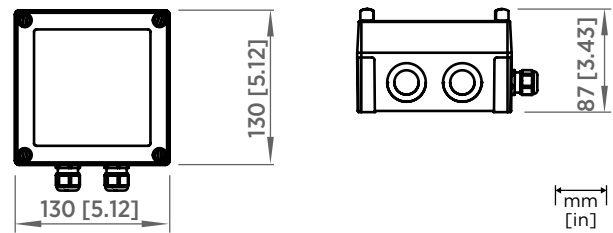

Bluetooth module enclosure dimensions

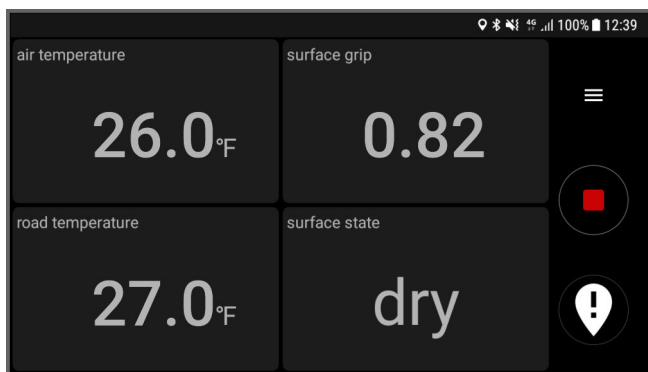

Data visualization on Vaisala RoadAI phone app

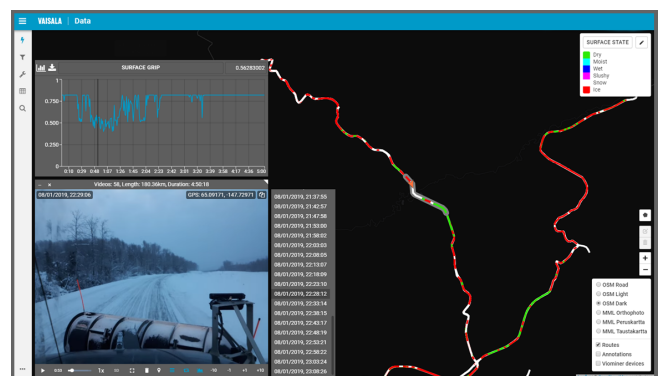

Data visualization on Vaisala RoadAI online map



www.vaisala.com

Published by Vaisala | B211719EN-D © Vaisala Oyj 2019

All rights reserved. Any logos and/or product names are trademarks of Vaisala or its individual partners. Any reproduction, transfer, distribution or storage of information contained in this document is strictly prohibited. All specifications – technical included – are subject to change without notice.