

ER08-S & ER08-SE PYRANOMETER for Solar Global Radiation

Integrating Cavity SECONDARY STANDARD PYRANOMETER



The Middleton Solar ER08-S exceeds the ISO 9060 specifications for a very high quality Secondary Standard Pyranometer. The ER08-S features an innovative new design of detector to give very low zero off-set and fast thermopile response. The ER08-SE version has an in-built amplifier with a millivolt output for easy signal measurement.

Performance Specification	ISO 9060 Secondary Standard	ER08-S and ER08-SE
Response time (to 95%)	< 15 sec	0.3 sec
Zero off-sets	(ventilated)	(ventilated or unventilated)
A) thermal radiation (200 W.m ⁻²)	+ 7 W.m ⁻²	< ± 0.2 W.m ⁻²
B) temperature change (5K/hour)	± 2 W.m ⁻²	< ± 0.2 W.m ⁻²
Non-stability (per year)	± 0.8%	< 0.1%
Non-linearity (100-1000W.m ⁻²)	± 0.5%	< ± 0.2%
Directional response (1000 W.m ⁻²)	± 10 W.m ⁻² (30-80°)	< ± 10 W.m ⁻² (0-80°)
Spectral selectivity (0.35 to 1.5µm)	± 3%	< ± 3%
Temperature response (for 50K interval)	± 2%	< ± 1% (-20 to +60°C)
Tilt response (0-90°)	± 0.5%	< 0.2%

ALMOST NO ZERO OFF-SET VERY FAST RESPONSE

Ground-breaking new design > Integrating Cavity Pyranometer

Reduced measurement uncertainty > hidden off-sets are insignificant

Suitable for all precision Meteorological and Industrial applications

Very fast response time is ideal for solar Photovoltaic Power Plant monitoring

Single glass dome gives lower directional error than conventional double dome configuration

Middleton Solar ER08-S & ER08-SE Pyranometer Detailed Specification

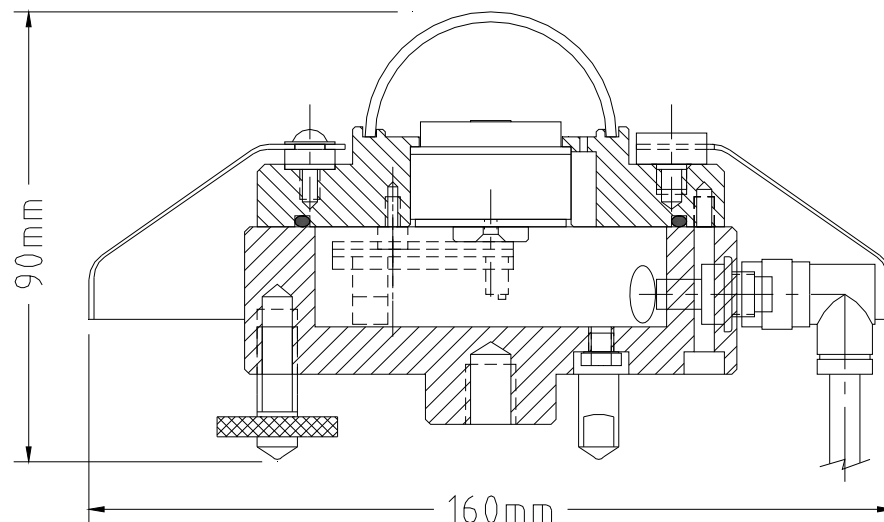

Detector incorporates a cosine-corrected entrance aperture, a compact integrating cavity, and an encapsulated thermopile with a FOV restricted to the cavity.

General Specification

viewing angle	2π steradians
irradiance	0 - 4,000 W/m ²
spectral range	285 – 3,000nm (50% points)
sensitivity (typical)	ER08-S: 7 μ V/W.m ⁻² ; ER08-SE: 1 mV/W.m ⁻²
achievable resolution	0.1 W.m ⁻²
expected output signal (0 – 1,500 W/m ²)	ER08-S: 0 to 15 mV; ER08-SE: 0 to 1.5V
initial calibration uncertainty (k=2)	< \pm 1.5% (traceable to WRR)
achievable daily uncertainty	2% (95% confidence level)
output impedance (nominal)	ER08-S: 6 K Ω ; ER08-SE: 65 Ω
measurement input impedance	> 10M Ω recommended for ER08-S
power requirement	ER08-S: none; ER08-SE: 5 -15 VDC, < 6mA
operating temperature	-40 to +80°C
operating humidity	0-100% RH
bubble level resolution	0.1°
level adjustment	one fixed foot, two adjustable feet
detector type	thermopile
dome window	ground from solid optical glass blank; Schott N-BK10
construction	anodized marine-grade aluminium & stainless steel
desiccant	orange silica gel (non-toxic)
IP rating	sealed to IP67
mounting method	central M10 hole in base (mounting knob supplied), or two M4 holes on 65mm P.C.D.
output lead	6m, with connector at instrument end
User's Guide & Calibration Certificate	included
net weight	0.8Kg
shipping size & weight	230 x 230 x 180mm, 2Kg

Available Options

- temperature output (ER08-S only), YSI 44031 thermistor (10K Ω @ 25°C)
- additional output lead length, up to 20m
- EV2-H Ventilator / Heater Unit